

## BLOCK TO BLOCK SHOOTING DRILL

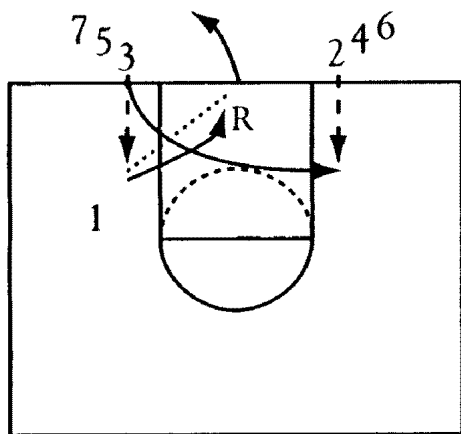

#3 passes to #1 who takes the short jumper. #3 loops through the lane, receives the pass from #2, and shoots. #1 follows the shot and goes to the back of #3's line.

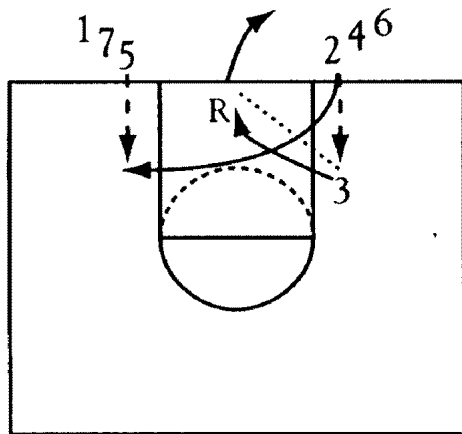

#3 follows the shot and goes to the back of #2's line. #2 loops through the lane, receives the pass from #5, and shoots.

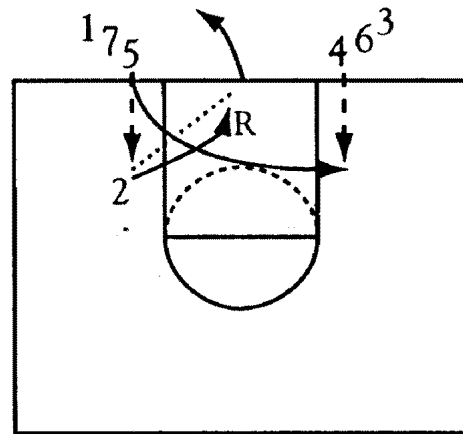

#2 follows the shot and goes to the back of #5's line. #5 loops through the lane, receives the pass from #4, and shoots. The drill continues.