

(Man-to-Man) OFFENSIVE PLAY: SINGLE

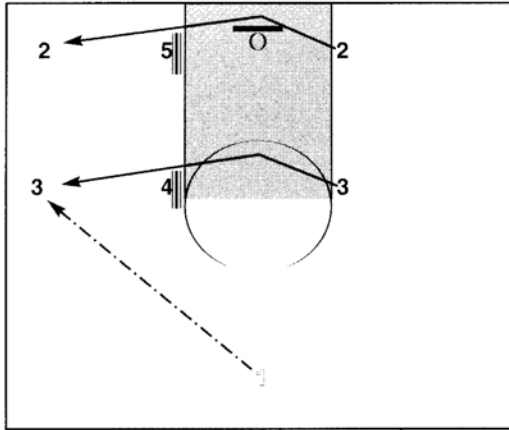

NOTES:

FRAME 1

Play will only be ran to the left side of the floor. 3 cuts to the middle of the key and breaks out to the left offensive wing off of 4's pick. 2 runs the baseline to the corner off of 5's pick.

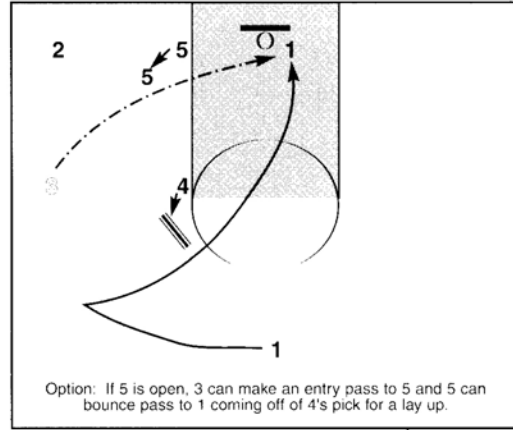

NOTES:

FRAME 2

5 must step out off of the block and post up hard asking for the ball bring his man to him (decoy) to clear out the weak side of the floor. 3 will receive the pass from 1 and 4 will pop back up top above the elbow. 1 will dip his man in front of 4's pick and take the pick on the high side looking for the lob from 3.

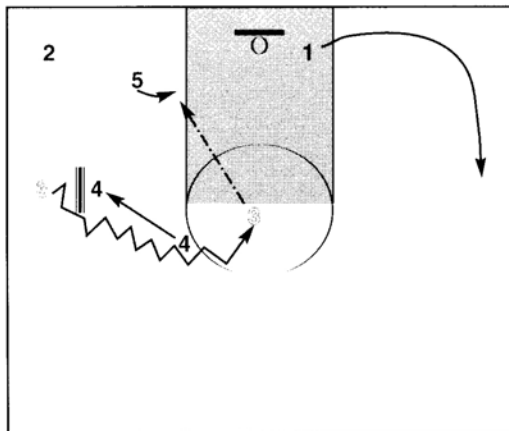

NOTES:

FRAME 3

If 1 doesn't pop open off of 4's back pick, then 4 immediately goes to pick for the ball. 1 will circle back out to the opposite side of the court back out to the top. 5 will post up hard in the low post fighting for position for the entry pass from 3

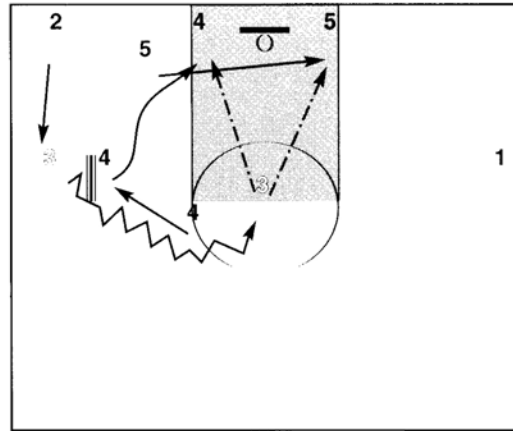

NOTES:

FRAME 4

5 can cross over to the other low post as 3 uses 4's pick to create room for 4 to roll to the basket. 2 will replace the left wing after it is vacated. 3 has jump shot at the foul line, or has 4 rolling to the basket off of his pick, or has 5 in the right block posting up hard after crossing through the key.