

(Man-to-Man) OFFENSIVE PLAY: NUGGET

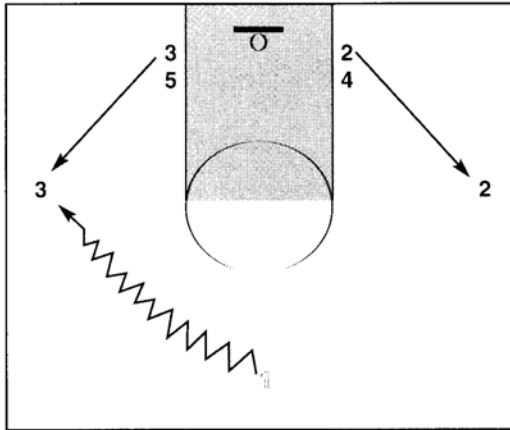

NOTES:

FRAME 1

4 and 5 set pick for 3 and 2 to get open on the wings for pass from 1. Play ran to the left side of the court. 1 dribbles toward 3 and pushes 3 out of the wing.

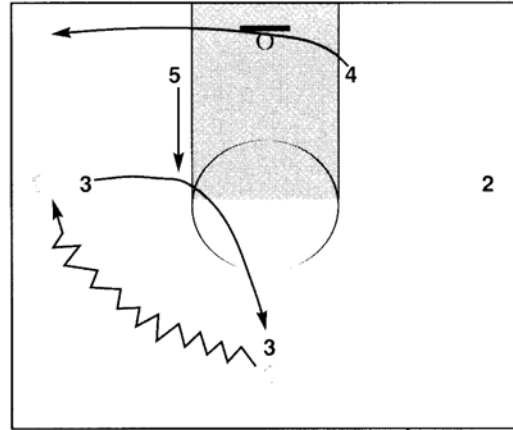

NOTES:

FRAME 2

3 will take his route to the elbow then up to the top to replace where 1 just came. 5 slides up to the elbow asking for the ball from 1 in the high post. 5 must really ask for the ball as a decoy getting down low sealing off and clapping for the pass.

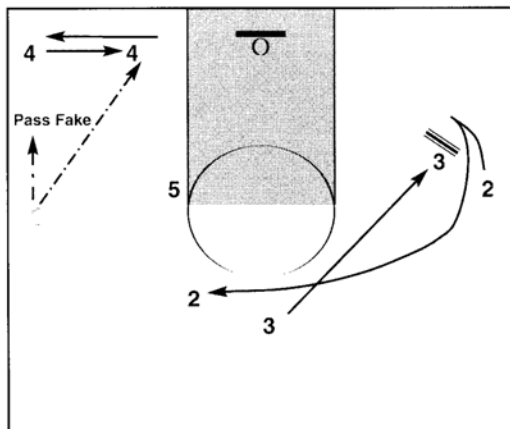

NOTES:

FRAME 3

4 hustles over to the ball side corner, bringing his man with him. 1 pass fakes to 4 in the corner and then back door cuts for the pass from 1 for the easy dunk or lay up. Once 3 arrives at the top, he will then go to set a pick for 2 to come to the top in case 4 doesn't pop open. 2 must misdirect and v-cut off of 3's pick, then 1 could then release to 2 up top to reset if 4 isn't open.

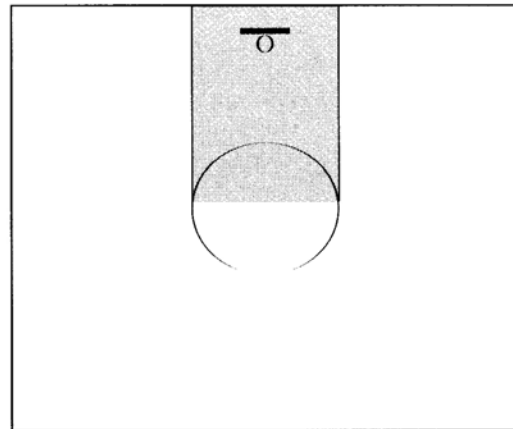

NOTES:

FRAME 4

This is a great set to run when the defense tightens up and needs the ball. When your up five or seven late in the game and your opponent must deny everywhere. This is also a great set to run when an opponent subs allowing 4 to be the player who is defended by the opponent's new player in the game. That sub will hustle himself right out of the play for a wide open back door dunk or lay up.